



ISSN: 2230-9926

Available online at <http://www.journalijdr.com>

IJDR

International Journal of  
DEVELOPMENT RESEARCH

International Journal of Development Research  
Vol. 4, Issue, 3, pp. 588-591, March, 2014

## Full Length Research Article

### FUZZY CONTROLLED FLY BACK CONVERTER FOR SOLAR ENERGY SYSTEM

\*Radhakrishnan, N. and Ramaswamy, M.

Department of Electrical Engineering, Annamalai University, Annamalai nagar, TamilNadu-608002

#### ARTICLE INFO

##### Article History:

Received 08<sup>th</sup> January, 2014  
Received in revised form  
11<sup>th</sup> February, 2014  
Accepted 15<sup>th</sup> February, 2014  
Published online 14<sup>th</sup> March, 2014

##### Key words:

PV system,  
Fly back converter,  
MPPT,  
Fuzzy

#### ABSTRACT

The paper develops a duty cycle control for the fly back boost converter using fuzzy based MPPT method. The photovoltaic (PV) systems exhibits nonlinear I-V characteristics and the maximum power point varies in accordance with solar radiation or insolation and temperature. The intermediate high frequency switched dc - dc converter increases the efficiency of the system by providing impedance matching between the PV system and the load. The innate nature of fuzzy principles introduces a reasoning theory to facilitate the operation of the PV cell arrays at their maximum power point. The MATLAB based simulation results leave way to realize a regulated output voltage over a range of operating loads and erudite its suitability for use in the practical world.

Copyright © 2014. Radhakrishnan, N. and Ramaswamy, M. This is an open access article distributed under the Creative Commons Attribution License, which permits unrestricted use, distribution, and reproduction in any medium, provided the original work is properly cited.

#### INTRODUCTION

The nefarious gases emanating from thermal power plants add to the agony in polluting the environment and pioneer the theory of global warming. The clean act promulgated by the government further emphasizes a renewed scope to address the harmful effects and offer resurgence to the overall energy perspective. The related issues surmount to resource depletion problems and create a strong focus for exploring the use of renewable energy sources that include solar, wind, biomass and fuel cells. The solar energy enjoys several advantages of clean, unlimited, and sustainable resource to offer alternatives and support the existing imbalance in the generation of electrical energy. Provide sustainable electricity in area not served by the conventional power grid. Solar cells turn out to be viable because of the absence of fuel cost, noise and wear and tear due to the absence of moving parts. The negligible maintenance cost for PV cell along with a longer lease of life cycle weighs its advantages to envisage an exquisite role in the energy crisis world. The solar energy system classifies itself into stand-alone power system and grid-connected power system. Though both systems inherit several similarities, still they remain different in terms of the requisite control functions. The stand-alone system finds exhaustive used in off-grid application with battery storage.

It augurs control etiquettes to foster a bidirectional battery charging and inverting operation. The renewable energy technologies appear to grow in consonance with the emerging trend in converter interfaces and oblige the artefacts of a green environment. Each of the three types of switched power converters respectively called buck, boost and buck-boost claim their own areas of use to suit specific needs. The interesting options in the use of these converters arouse a keen interest to contemplate on advances in controlling their operation. It percolates to exploit their wide applicability domain that ranges from domestic equipments to sophisticated utilities.

The output of the PV panels depends on surrounding weather conditions those are sun irradiance level and temperature (Kuo *et al.*, 2001; Masoum *et al.*, 2002; Fangrui *et al.*, 2008). Generally, a PV system consists of PV array and PV power conditioner that can be divided into two categories, first is dc-dc converter to control the dc voltage and second is inverter to generate ac power (Kasa *et al.*, 2005). A fuzzy based P&O algorithm is proposed to implement in a flyback inverter with centre-tapped secondary winding. The design of this circuit was presented in (Kasa and Iida, 2002; Shimizu *et al.*, 2002). The flyback inverter can directly convert the specified dc power to ac power. Modulation index (flyback inverter) and duty-cycle (DC-DC converter) are key parameters for tracking MPP of solar array (Nicola Femia *et al.*, 2005). A thorough analysis of the DCM flyback inverter is described (Kyritsis *et*

\*Corresponding author: Radhakrishnan, N.  
Department of Electrical Engineering, Annamalai University,  
Annamalai nagar, TamilNadu-608002

al., 2008). Fuzzy is able to work properly even without the precise knowledge of system and is more robust compared to the conventional non-linear controller (Chin *et al.*, 2003). The dc-dc converters have been explored extensively to meet the required electric energy demands by these systems using a battery back-up (Zhao and Lee, 2003). Detailed performance analysis is carried out for analyzing the controller performance in varying loading conditions (Knapp and Jester, 2001). A low cost solution for controlling duty cycle of switches has been proposed and a constant output voltage at varying loads has been realized (Weidong Xiao *et al.*, 2007; Mohan *et al.*, 2003). However it still becomes significant to conceive better control formulations to track the maximum power of a solar energy system and ensure its capability to trade off the system's perturbations.

**Problem Statement**

The primary focus endeavours to involve fuzzy theory in articulating the MPPT algorithm with a view to track the maximum power output from a solar stacked system. The adjoining philosophy extends to cascade the operation of a fly back boost converter together with its switching scheme to admonish a regulated output voltage and adequately remain interfaced with the grid. The exercise stretches to examine the performance of the system and establish the credibility of the reasoning principles through simulation study.

**MATERIALS AND METHODS**

The scheme of power conditioning which transmits the power to the load from the cell always requires high efficiency over a stretch of varying loads. However the output power from the solar cell changes in light of the environmental conditions like irradiation and temperature and the efficiency goes down. The conversion of power accomplished through a dc to dc converter using the philosophy of maximum power point tracking exults to augment the pattern of power and emerge out with the required level of output. The power module of the chosen Fly back converter is seen in Fig.1. The output of the PV cell is given as input to the fly back converter. The fuzzy based MPPT controller receives the output voltage and current of the PV system, reference voltage and actual load voltage. The output of the controller is the PWM pulses with required duty cycle.

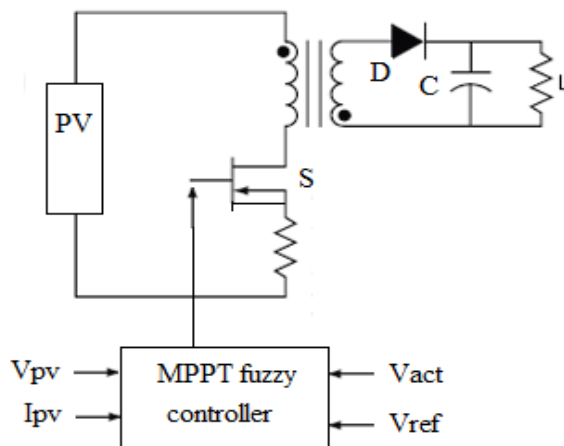

**Fig. 1. Power circuit**

**Mathematical Model of PV System**

PV cell is a p-n junction semiconductor, which converts light into electricity. When the incoming solar energy exceeds the band-gap energy of the module, It travels to absorb photons from the materials to generate electricity. The equivalent-circuit model of PV seen in Fig.2 consists of a light-generated source, diode, series and parallel resistances.

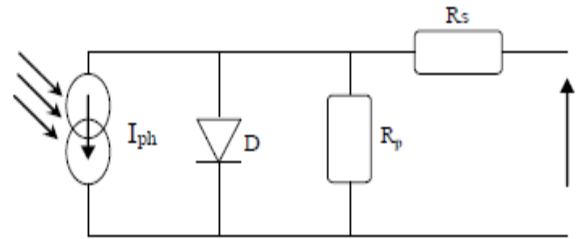

**Fig. 2. Equivalent circuit of PV model**

The equations 1 through 3 describe the electric behaviour of the PV panel under constant irradiance and temperature

$$I(V_{PV}) = \frac{I_x - I_x e^{\left(\frac{V_{PV} - 1}{bV_x}\right)}}{1 - e^{\left(\frac{1}{b}\right)}} \tag{1}$$

$$V_{PV}(I) = bV_x \ln \left[ \frac{I_x - (I - I_x e^{\left(\frac{1}{b}\right)})}{I_x} \right] + V_x \tag{2}$$

$$P(V_{PV}) = V_{PV}I = \frac{V_{PV}I_x - V_{PV}I_x e^{\left(\frac{V_{PV} - 1}{bV_x}\right)}}{1 - e^{\left(\frac{1}{b}\right)}} \tag{3}$$

The output current of the PV panel is translates to be equal to the average input current of the DC-DC converter. The expression in 4 relates to the maximum power of the PV panel.

$$P_{max} = V_{op}I_{op} = V_{op} \frac{I_x - I_x e^{\left(\frac{V_{op} - 1}{bV_x}\right)}}{1 - e^{\left(\frac{1}{b}\right)}} \tag{4}$$

**Maximum Power Point Algorithm**

Fig.3 shows the operating flowchart of MPPT algorithm, Vpv and Ipv are output voltage and current of PV array and Δv is the value of variation in voltage to compute next voltage value. For a given disturbance on the voltage of the panel leads to an increase (decrease) the output power of the PV. As a consequence, when the MPP is reached, the system may oscillate around it and this problem is overcome by reducing the disturbance step size.

**Fuzzy Model**

The principle behind the creation of fuzzy model traverses to use imprecise data and classify into sets rather than the sharp boundaries. It manifests to provide a framework for approximate reasoning in the face of ambiguous and uncertain information. The fuzzy logic controller (FLC) embodies to search for the suitable value of the duty cycle at which the power switches require to operate in order that the maximum

power reaches at a particular operating point. The block diagram of the FLC shown in Fig. 4 engages to create the rule base.

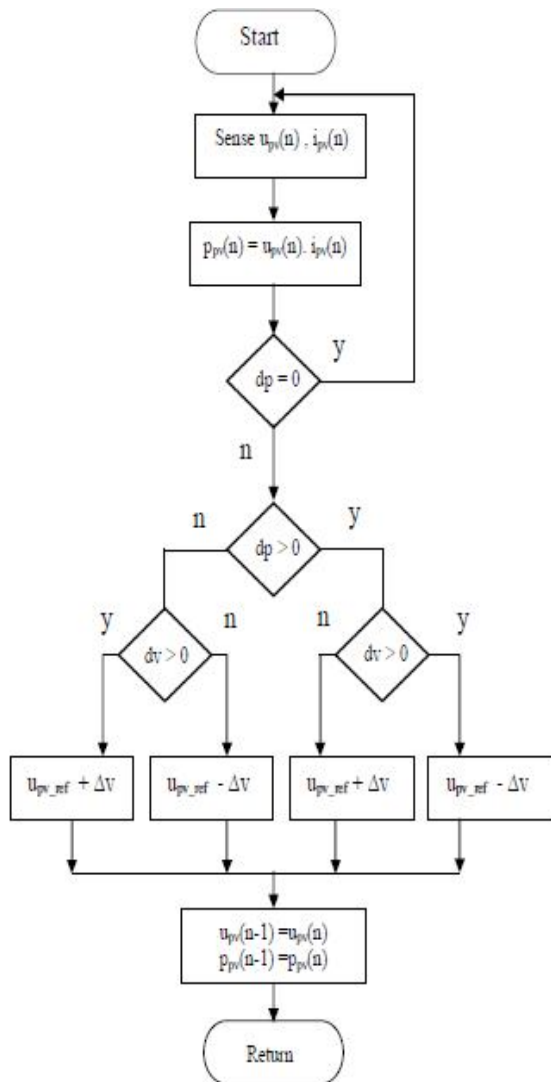

Fig. 3. Flow diagram for MPPT algorithm

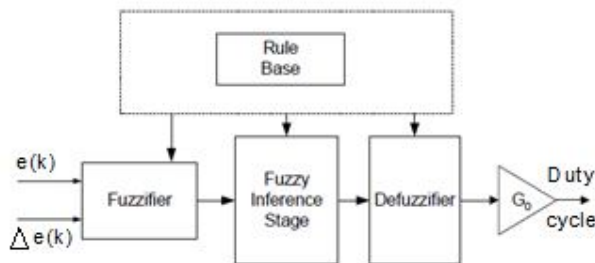

Fig. 4. Block diagram of fuzzy controller

The scheme avails a total of five heuristically chosen membership functions to describe each of the input and output variables of the controller. The procedure carries the role of uniformly distributed, symmetrical triangular membership functions throughout, except for the outer membership function which saturates at  $\pm 1$  as depicted in Fig. 4. The input linguistic variables are ‘e’, the error and ‘ce’, the change in error; and the output linguistic variable is ‘u’, the duty cycle.

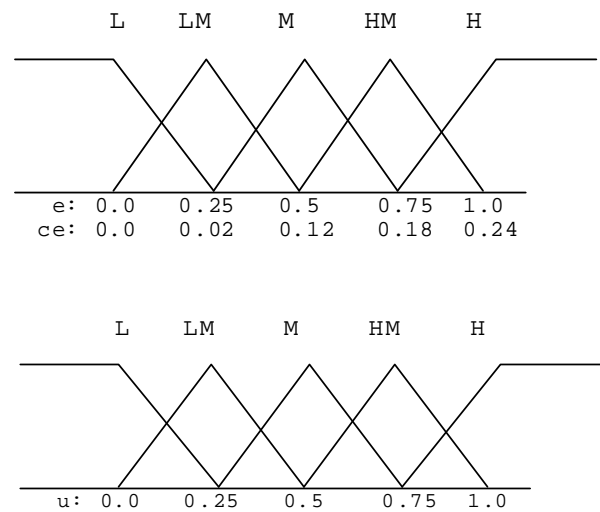

Fig. 5. Membership functions chosen for linguistic variables

The fuzzified controller real-valued input variables map onto the input membership functions. Each linguistic variable can pick up a numeric linguistic value from very large negative to very large positive and the entries in Table 1 include the designed rule-base in terms of linguistic values. The defuzzification stage engulfs the Centre of Gravity (CoG) method on the implied fuzzy sets to generate a crisp output.

Table 1. Fuzzy Decision Matrix

AND		CE				
		L	LM	M	HM	H
E	L	LM	LM	L	L	L
	LM	M	LM	LM	L	L
	M	M	M	LM	LM	L
	H	HM	M	M	LM	LM
	H	H	HM	M	M	LM

## RESULTS AND DISCUSSION

The effectiveness of flyback converter and the proposed fuzzy system are verified by simulation with Matlab/Simulink. Flyback converter is modelled in MATLAB. The PV system adopted in this study is composed of 200W and Fly back converter with 20 kHz switching frequency. Figs. 6 and 7 show the I-V and P-V characteristics of the PV array.

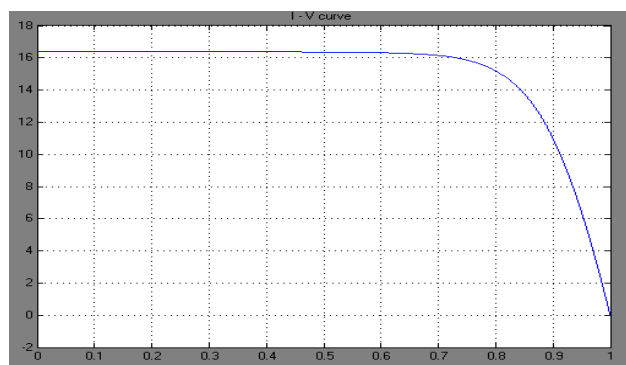

Fig. 6. I-V curve

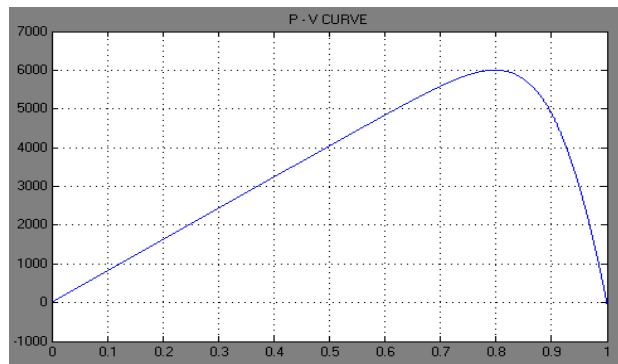

Fig. 7. P-V curve

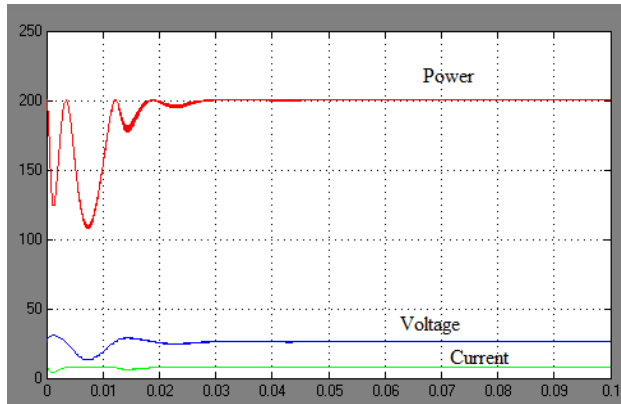

Fig. 8 Voltage current and power waveforms

Fig. 8 shows the results of power, voltage and current from the proposed MPPT algorithm when operated at irradiance level = 1000 W/m<sup>2</sup>.

Table 2. Performance results

Load Power (W)	Load current (A)	Load voltage (V)
50	0.22	230
100	0.43	230
150	0.65	230
200	0.87	230

The entries in Table 2 depicts the voltage regulation capability of the controller with changing loads

## Conclusion

A Fuzzy based control strategy has been developed for a solar energy system to extract the maximum power from a photovoltaic array in varying weather conditions. The merits of MPPT search algorithm have been incorporated to abstract the optimal power. The operational sequence of a Fly back converter has been epitomized as an exquisite interface to realize the precise power output of the load. The steady and transient states simulation results have been projected to illustrate the effectiveness of the proposition and demonstrate its capability to meet the delicacies of sophisticated loads. The ability of the controller to tailor itself to a varying irradiation scenario will go a long way in unleashing fresh directions to exploit the benefits of solar energy.

## REFERENCES

- Kuo, Y-C., T-J. Liang and J-F. Chen, "Novel Maximum Power-Point- Tracking Controller for Photovoltaic Energy Conversion System", IEEE Transactions On Industrial Electronics, Vol. 48, No. 3, June 2001, pp.594-601.
- Masoum, M. A. S., H. Dehbonei, and E. F. Fuchs, "Theoretical and Experimental Analyses of Photovoltaic Systems with Voltage- and Current-Based Maximum Power-Point Tracking", IEEE Transactions On Energy Conversion, Vol. 17, No. 4, December 2002, pp.514-522.
- Fangrui, L., Y. Kang, Y. Zhang, and S. Duan, "Comparison of P&O and Hill Climbing MPPT Methods for Grid-Connected PV Converter," 3rd IEEE Conference on Industrial Electronics and Applications, 2008, ICIEA 2008. pp. 804-807.
- Kasa, N., T. Iida, L. Chen, "Flyback inverter controlled by sensorless current MPPT for photovoltaic power system," IEEE Trans. Ind. Elec., vol. 52, no. 4, pp. 1145-1152, 2005.
- Kasa, N. and T. Iida, "A flyback type inverter for small scale wind power generation system", Dept. Electron. Eng., Okayama Univ. Science, Okayama, Japan, Tech. Rep. SPC-02-16, Feb. 2nd, 2002.
- Shimizu, T., K. Wada, and N. Nakamura, "A flyback-type single phase utility interactive inverter with low-frequency ripple current regulation on the DC input for an AC photovoltaic module system", IEEE 33rd Annual on power electronics., Vol. 3, pp. 1483-1488, 2002.
- Nicola Femia, Giovanni Petrone, Giovanni Spagnuolo, "Optimization of Perturb and Observe Maximum PowerPoint Tracking Method," IEEE Trans. on Power Electronics, Vol. 20, No. 4, pp. 963-973, 2005.
- Kyritsis, A.Ch.; Tatakis, E.C. Papanikolaou and N.P, "Optimum Design of the Current-Source Flyback Inverter for Decentralized Grid-Connected Photovoltaic Systems," IEEE Transactions on Energy Conversion, Vol. 23, No. 1, pp. 281–293, 2008.
- Chin, C.S., P. Neelakantan, H.P. Yoong, S.S. Yang and K.T.K. Teo, "Maximum power point tracking for PV array under partially shaded conditions," Proceedings of 3rd International Conference on Computational Intelligence, Communication Systems and Networks, Bali, Indonesia, pp. 72-77, 2011.
- Zhao, Q. and F. C. Lee, "High-efficiency, high step-up DC-DC converters," IEEE Trans. on Power Electronics, vol. 18, no. 1, pp. 65-73, Jan. 2003.
- Knapp, K. and T. Jester, "Empirical investigation of the energy payback time for Photovoltaic modules," Solar Energy, vol. 71, no. 3, pp. 165-172, 2001.
- Weidong Xiao, Nathan Ozog and William G. Dunford, "Topology Study of Photovoltaic Interface for Maximum Power Point Tracking," IEEE Trans. on Industrial Electronics, vol. 54, no. 3, pp. 1696-1674, June 2007.
- Mohan, N., N. Undeland, M. Robbins, 'Power Electronics Converters, Applications and Design,' John Wiley & Sons, USA, 2003.

\*\*\*\*\*